

**HMI** Hoyme Manufacturing Inc. **Special Note: Circuits are colored for clarification only and are not necessarily those found in actual installations. Combustion Air Damper Wires, however, are colored as shown.**

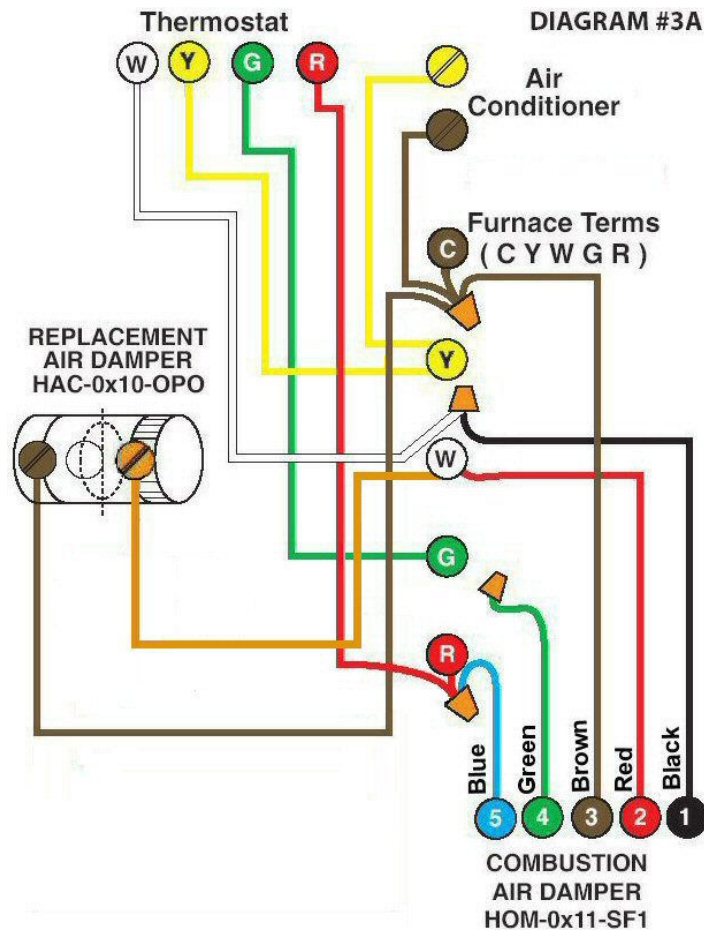

**Diagram #3A:** Forced Air Furnace having a fresh air **supply duct for combustion** and a **replacement air supply duct** leading to the return plenum.

**ADDED:** 1. **Combustion Air Damper (HOM-0x11-SF1)** 2. **Replacement Air Damper. (Power Open) (HAC-0x10-OPO)**

**OPERATION:** 1. **Combustion Air Damper** is interlocked to the thermostat so that the damper proves to be open to supply fresh air for combustion before the furnace fires. The damper closes to **conserve energy** when the fire stops. 2. **Replacement Air Damper** is interconnected to the thermostat so that the damper opens to provide fresh air into the return plenum only during the heating cycle and will close to provide comfort and conserve energy when the fire stops. Heat Anticipator adjustment may be required on a regular type thermostat. The damper will also remain closed during furnace fan operation. To **override the normally closed damper to remain open**, see **Diagram 3A1**.

**N.B.** Replacement Air Damper is not affected by the 'Manual' setting of the furnace fan.

Additional Colored Wiring Diagrams are shown on the web at [www.hoyme.com](http://www.hoyme.com)